

Calculate the overall NF of this RX

- Duplexer: split RX and TX paths in full duplex TRX (e.g. LTE) -> isolation
- IRF provides attenuation at $2f_{LO}-f_{RF}$; alternative use image reject mixer
- IF filter is used to improve linearity of IF amp and baseband
- From mixer output, 500Ω R_s/R_{out} , P gain is $10\text{dB} < V$ gain ($10\log(R_{in}/R_{out})$)

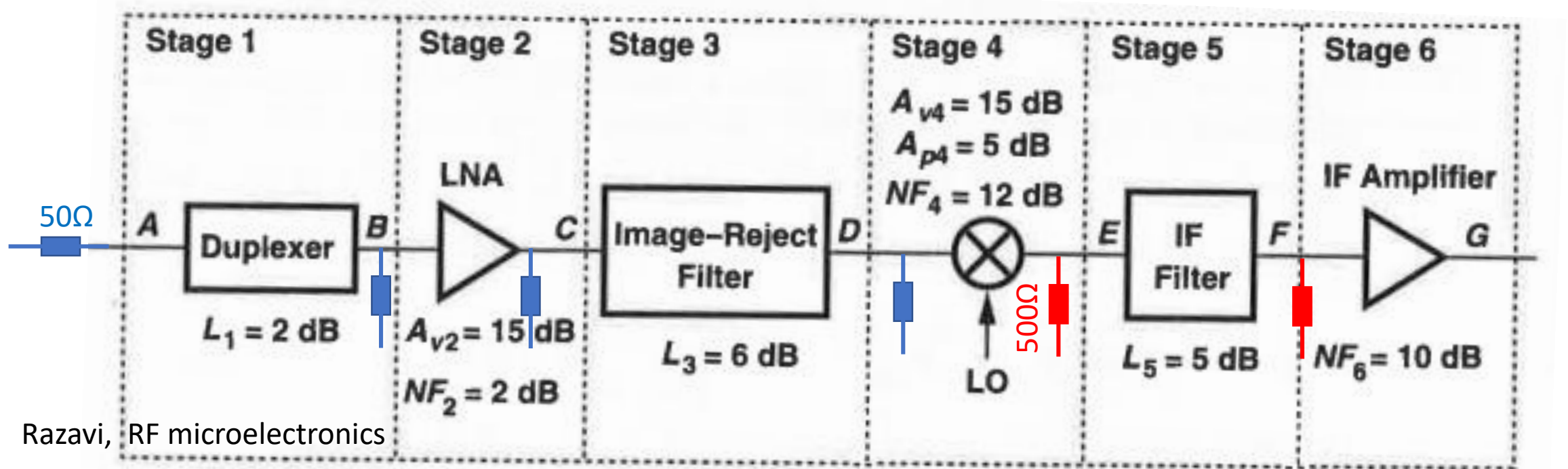

Calculate the overall NF of this RX

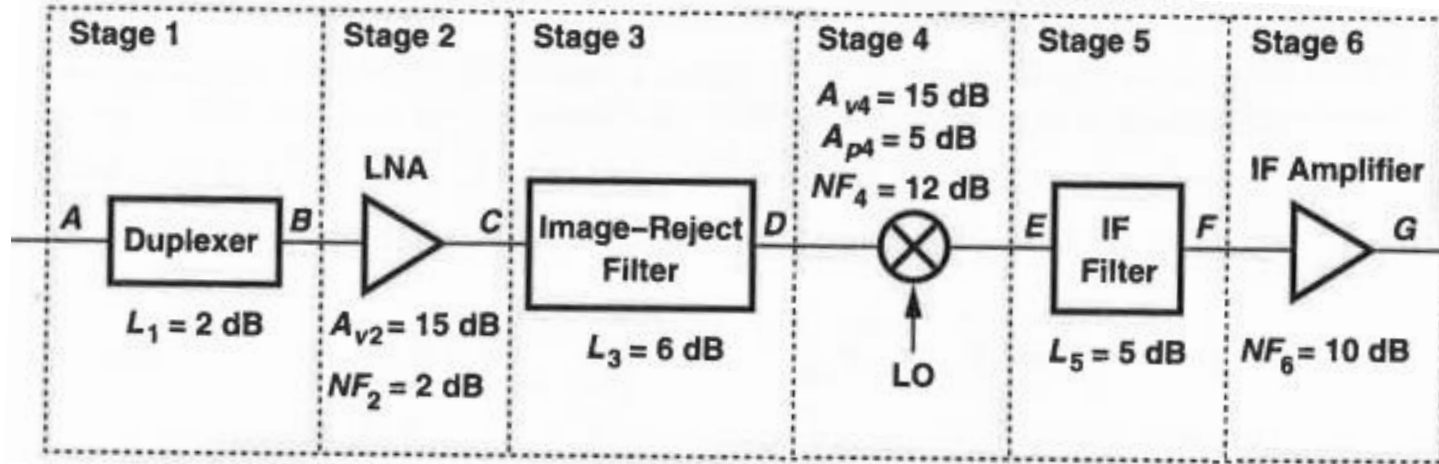

- We may use directly the Friis equation or calculate recursively from node F to node A (we want to get the input total NF to get sensitivity)

- Two stages formula nice to see how each block NF is degraded

- Easy to retrieve Friis one

$$F_{n-1_tot} = F_{n-1} + \frac{(F_n - 1)}{G}$$

- The NF of a lossy element is equal to its insertion loss (L)

- Simply add L in dB to the NF

$$F_{n-1_tot} = L + \frac{(F_n - 1)}{L^{-1}} = F_n \cdot L$$

Calculate the overall NF of this RX wo filters

- Compare with previous result